

---

# Instruction Manual

**DENVER CAP-4100**  
4 CHANNEL HIGH POWER AMPLIFIER

---

## Specifications

### AUDIO POWER SPECIFICATIONS

#### POWER OUTPUT AND TOTAL HARMONIC DISTORTION

60 watts per channel minimum continuous average power into 4 ohms, both channels driven from 20Hz to 20kHz with no more than 0.04% total harmonic distortion per Car Audio Ad Hoc committee standards.

Other specification

circuit system OTL (output transformer less) circuit, pulsc power supper  
input RCA pin jacks

Outputs 4 channels speaker terminals

speaker impedance 2-16  $\Omega$  (stereo)  
4-8  $\Omega$  (when used as a bridging amplifier)

Maximum outputs five speaker:  
120W $\times$ 4  
four speaker  
120W $\times$ 2+240W $\times$ 1  
three speaker  
240W $\times$ 2

Rated output(supply voltage at 14.4v)  
five speaker:  
60W $\times$ 4(20Hz-20kHz, 0.1% THD)  
four speaker  
60W $\times$ 2+120W $\times$ 1(20Hz-20kHz, 0.1% THD)  
three speaker  
120WX2 (20Hz-20kHz)

frequency response 20Hz-40kHz (+0.5dB-3dB)

Harmonic distortion 0.04%or less (at 1kHz)

input level adjustment range  
0.2-0.6v(RCA pin jack)

High pass filter 50-500Hz , -9dB/ OCT

Low Pass filter 50-250Hz, -9dB/oct

Low boost 0-6-12dB(40Hz),three level

power supply voltage 10.5-15v

Design and specifications are subject to change without notice,

## Features

- Maximum power output of 120 watts per channel
- This unit can be used as a bridging amplifier with a maximum output of 240 watts.
- Built-in variable LPF (low-pass filter), HPF(high-pass filter)and low boost circuit .
- Protection circuit and indicator provided.
- Pulse power supply\* for stable, regulated output power.

### Pulse power supply

this unit had built-in power regulator which converts the power supplied by the DC12v car battery into high speed pulses using a MOS-FET semiconductor switch, These pulses are stepped up by the built-in pulse transformer and separated into both positive and negative power supplies before being converted into direct current again ,this is to regulate fluctuating voltage from the car battery, This light weight power supply system provides a highly efficient power supply with a low impedance output.

# Troubleshooting Guide

The following checklist will assist in the correction of most problems which you may encounter with your unit. Before going through the connection and operating procedures.

Problem	Cause / solution
The power indicator does not light up.	<ul style="list-style-type: none"> <li>The fuse is loose or blown -- fasten the fuse or change it with a new one</li> <li>The ground lead is not securely connected -- fasten a metal point of the car</li> <li>the voltage going into the remote terminal is too low</li> <li>the connection master unit is not turned on, -turn on the masternuit.</li> <li>the system employs too many amplifiers.--use a relay. Check the battery voltage (10.5-15V)</li> </ul>
Turn off , The protection indicator light up in red	<p>The speaker outputs are short -circuited.--Turn off power switch, Rectify the cause of the short -circuit and correct. The unit heats up abnormally or operating temperature.</p> <ul style="list-style-type: none"> <li>Use speakers with suitable impedance--2-8 Ω (stereo), 4-8 Ω (when used as a bridging amplifier)</li> <li>make suer to place the unit in a well ventilated location.</li> </ul>
Alternator noise is heard.	<p>The power connecting leads are installed too close to the RCA pin cords.--Tidy these connecting leads and keep the leads away from the cords.</p> <ul style="list-style-type: none"> <li>The ground lead not securely connected--Fasten the ground lead securely to a metal point of the car.</li> <li>Negative speaker leads are touching the car chassis.--Keep the leads away from the car chassis.</li> </ul>
The sound is muffled.	The FILTER switch set to the "LPF" position.
The sound in too low.	The level adjustment control is set "MIN"position.

## Location and function of controls

- POWER indicator**  
Lights up in green during operation.
- PROTECTOR indicator OVER CURRENT:**  
lights up in red when output is powerful or speaker short-circuit,  
**OFFSET:**  
lights up in red when the voltage going out to the speaker terminal or the pin jack is too high.  
**THERMAL:**  
lights up in red when the temperature rises to an unsafe level.
- FILTER selector switch**  
when the switch is in the LPF positions. the filter is set to low-pass. When in the HPF position, the filter is set to high-pass.
- Cut-off frequency adjustment control**  
Sets the cut-off frequency(50-250Hz) for the low-pass filter.
- LOW BOOST level control**  
turn this control to boost the frequencies around 40 Hz to a maximum of 12 dB.
- LEVEL adjustment control**  
the input level can be adjusted with this control when using source equipment made by other manufacturers, Tun it to MAX when the output level of the car audio seems low.
- Cut-off frequency adjustment control**  
Sets the cut-off frequency (50Hz-500 Hz) for the high-pass filter.

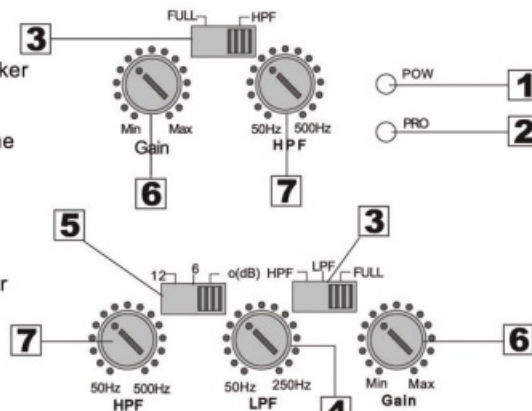

## Notes on the power supply

- Connect the +12V power supply lead only after all the other leads have been connected,
- Be sure to connect the ground lead of the unit securely to a metal point of the car, A loose connection may cause a malfunction of the amplifier,
- Be sure to connect the remote control lead of the car audio to the remote terminal,
- When using a car audio without a remote output on the amplifier, connect the remote input terminal(REM OTE)to the accessory power supply.
- Use the power supply lead with a fuse attached(40A),
- Place the fuse in the power supply lead as close as possible to the car battery,
- Make sure that the leads to be connected to the +12V and GND terminals of this unit are larger than 10-Gauge (AWG-10)or have a sectional area of more than 5 (mm)

## Precautions

- This unit is designed for negative ground 12V DCoperation only.
- Use speakers with suitable impedance.--2 to 16ohm(stereo).
- Do not connect any active speakers (with built-in amplifier)to the speaker terminals of the unit.
- Avoid installing the unit where:
  - it would be subject to high temperatures such as from direct sunlight or hot air from the heater.
  - it would be exposed to rain or moisture.
  - it would be subject to dust or dirt, If your car is parked in direct sunlight and there is a considerable rise in temperature inside the car, allow the unit to cool down before use.
- When installing the unit horizontally, be sure not to cover the fins with the floor carpet etc.
- If this unit is placed too close to the car radio, interference may occur. In this case, relocate the amplifier away from the car radio .
- If no power is being supplied to the master unit, check the connections.
- This power amplifier employs a protection circuit to protect the transistors and speakers if the amplifier malfunctions. Do not attempt to test the protection circuit by covering the heat dink or connecting improperloads.
- Do not use the unit on a weak battery as its optimum performance depends on s good power supply.
- For safety reasons, keep you car audio volume moderate so that you can still hear sounds outside your car.

## \*Protection circuit

this amplifier is provided with a protection circuit that operates in the following cases:

- when the unit is overheated
  - when a DC current is generated
  - when the speaker terminals are short circuited.
- The PROTECTOR indicator lights up in red and the unit will shut down. If this happens, turn off the connected equipment, take out the cassette tape or disc, and determine the cause of the malfunction, If the amplifier has overheated, wait until the unit cools down beforeuse.

## Installation

### Before installation

- Mount the unit either inside the trunk or under a seat.
- Choose the mounting location carefully so the unit will not interfere with the normal movements of the driver and it will not be exposed to direct sunlight or hot air from the heater.
- Do not install the unit under the floor carpet, where the heat dissipation from the unit will be considerably impaired.

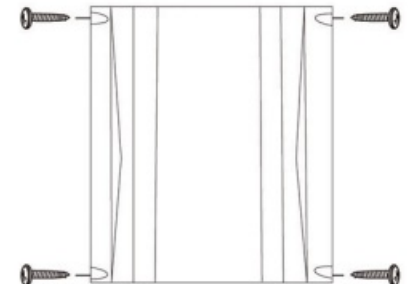

## 2-speaker system (with input connection B or D)

For details on the settings of switches and controls, refer to "Location and function of controls."

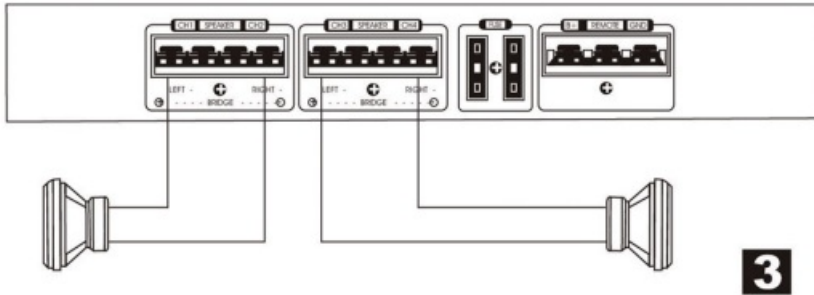

## 6-speaker system (with input connection A or C)

For details on the settings of switches and controls, refer to "Location and function of controls."

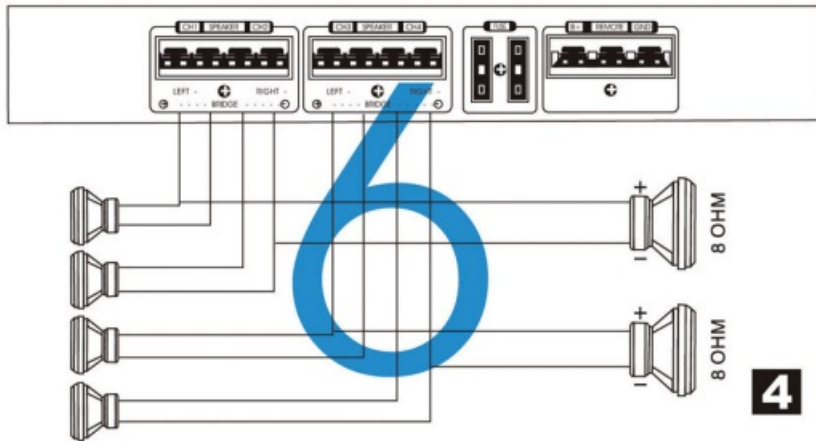

## power connection leads

Note  
in this system, the volume of subwoofers will be controlled by the car audio fader control

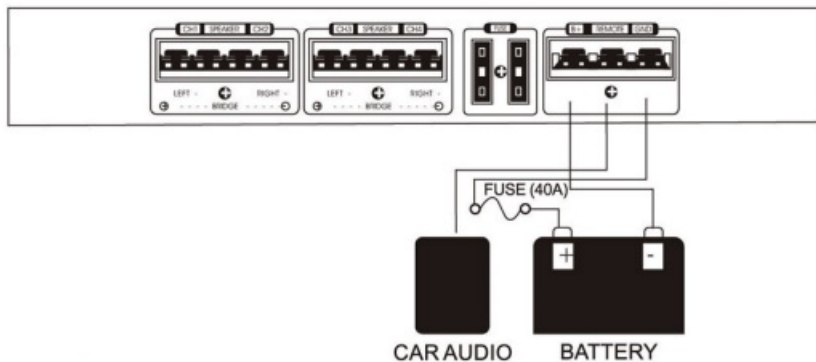

\*If you have the factory original or some other car audio without a remote out-put on the amplifier, connect the remote input terminal (REMOTE) to the accessory power supply.

## Fuse replacement

If the fuse blows, check the power connection and replace the fuse. If the fuse blows again after replacement, there may be an internal malfunction. In such a case, consult your nearest goods dealer.

### Warning

when replacing the fuse, be sure to use one matching the amplifier stated above the fuse holder. Never use a fuse with an amperage rating exceeding the one supplied with the unit as this could damage the unit.

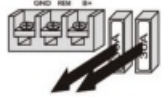

### Caution

- Before making any connections, disconnect the ground terminal of the car battery to avoid short circuits.
- Be sure to use speakers with an adequate power rating. If you use small capacity speakers, they may be damaged.
- Do not connect the "-" terminal of speaker system to the car chassis and do not connect the "-" terminal of the right speaker with that of the left speaker.
- Install the input and output cords away from the power supply lead as running them close together can generate some interference noise.
- This unit is a high powered amplifier, therefore, it may not perform to its full potential if used with the speaker cords supplied with the car.
- If your car is equipped with a computer system for navigation or some other purpose, do not remove the ground wire from the car battery. If you disconnect the wire, computer memory may be erased. To avoid short circuits when making connections, disconnect the +12V power supply lead until all the other leads have been connected.

### Make the terminal

connections as illustrated below.

### Note

tighten the screws firmly, but be careful not to apply too much force\* as doing so may damage these screws.

\*the torque value should be less than 1 N•m.

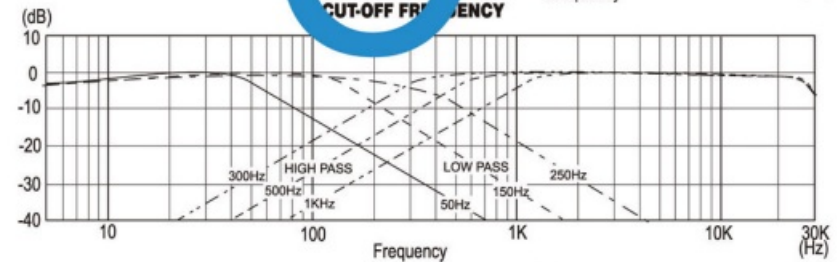
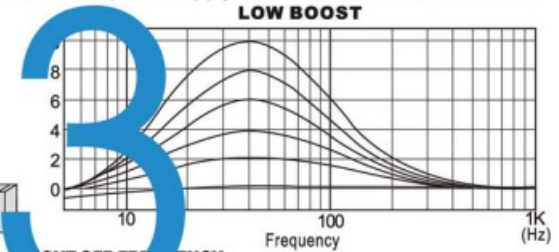
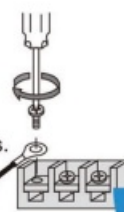

## Circuit diagram

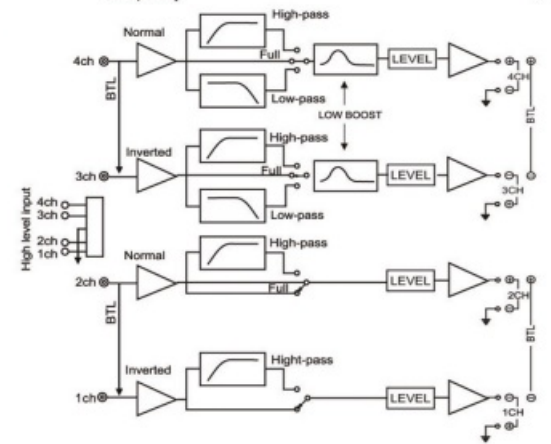

First, place the unit where you plan to install it, and mark positions of the four screw holes on the surface of the mounting board (not supplied). Then drill the holes approximately 3 millimeters (mm) in diameter and mount the unit onto the board with the supplied mounting screws. The supplied mounting screws are 15mm long. Therefore, make sure that the mounting board is thicker than 15mm.

# Input.connections

## Line input connection (with speaker connection 3)

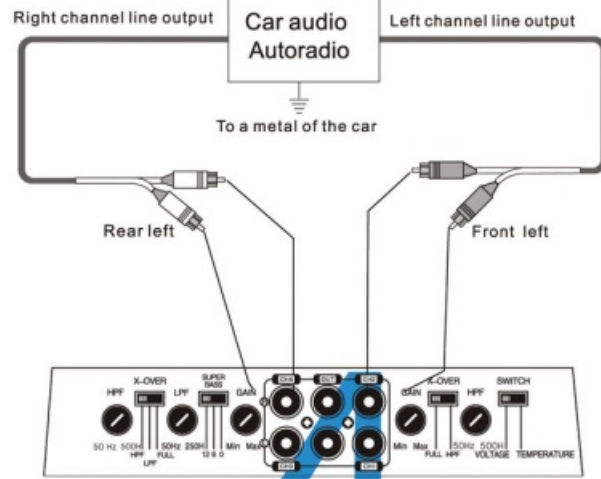

4

## Line input connection (with speaker connection 1, 2, or 4)

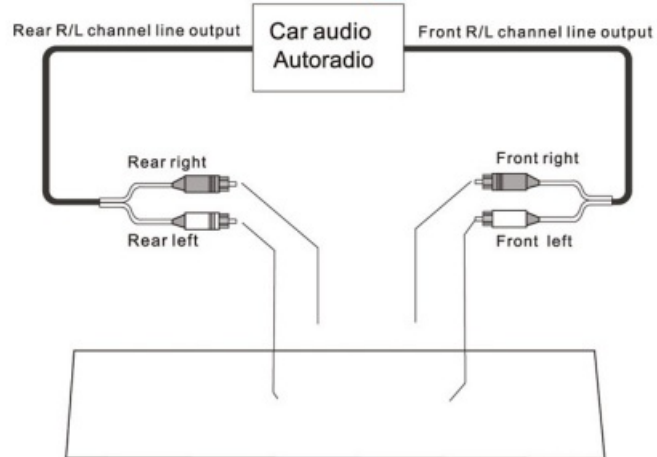

## 4-speaker system (with input connection A or C)

six details on the settings of switches and controls, refer to "Location and function of controls."

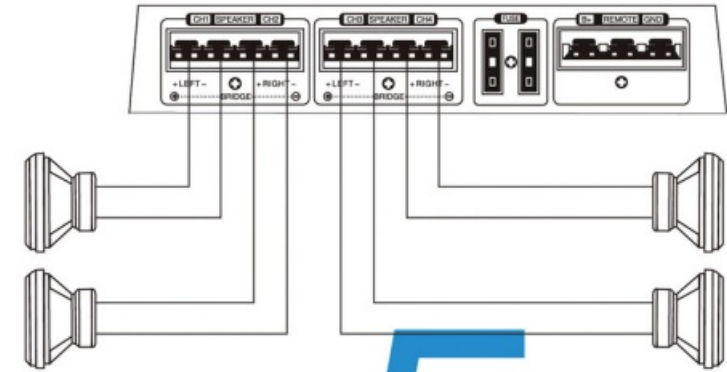

5

1

## 3-speaker system (with input connection A or C)

For details on the settings and controls, refer to "Location and function of controls."

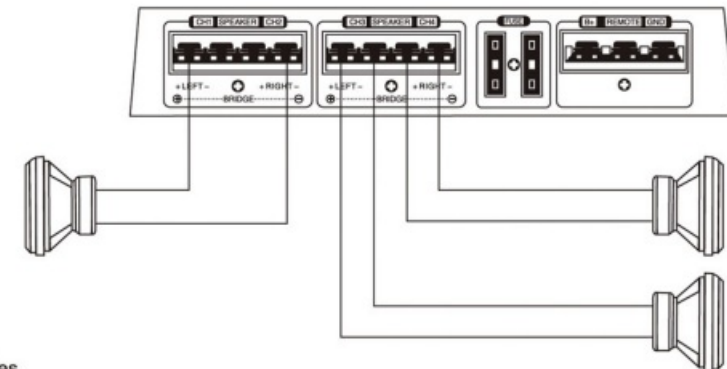

### Notes

in this system, the volume of the subwoofer will be controlled by the car audio fader control.

In this system, the output signals to the subwoofer are a combination of both the REAR L and R INPUT jack or the REAR high level input connector signals.

2